

CAD FILE:

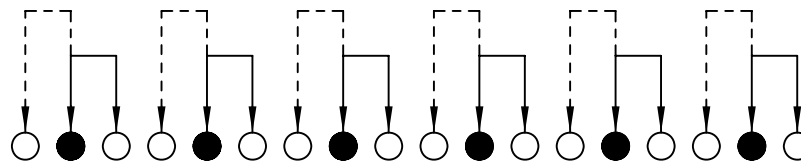

SCHEMATIC (SHORTING)

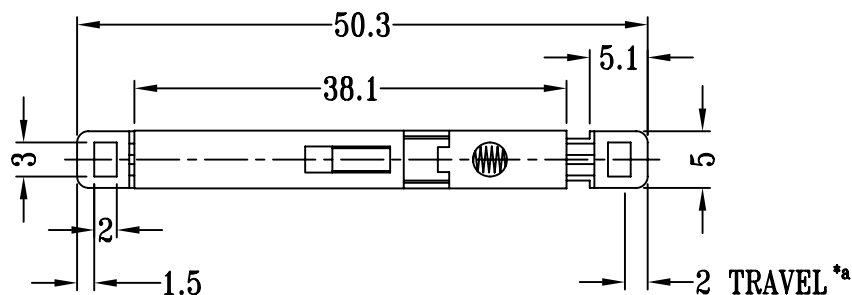
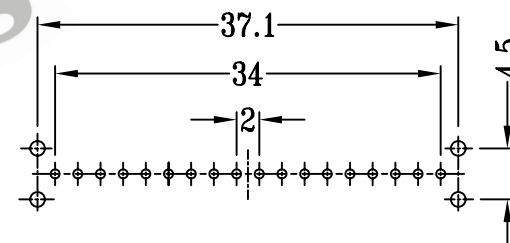
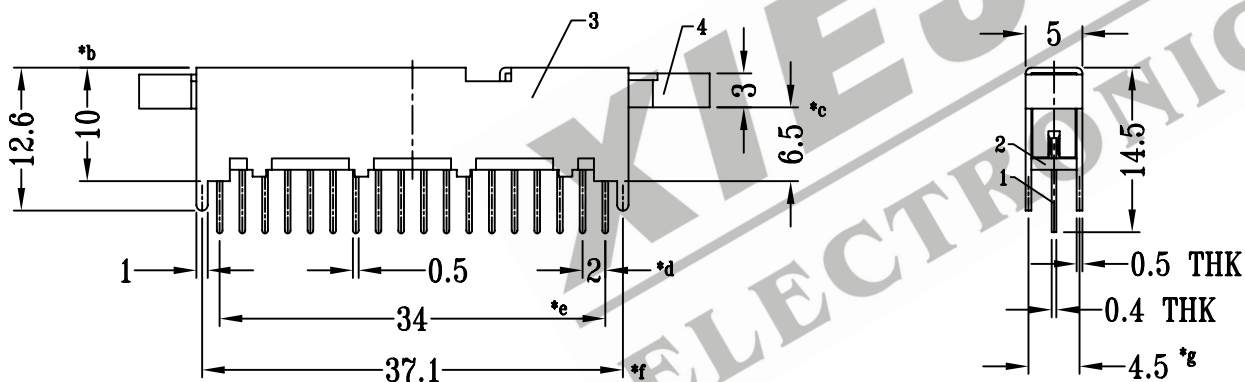

P.C.B LAYOUT

注:带"*"表示关键尺寸(7个)

				TOLERANCE UNLESS SPECIFIED	SHENZHEN XIEJIA ELECTRONICS CO.,LTD.				
8									
7									
6	SPRING	STEEL WIRE	1	NATURAL	WITHIN : 1.5±0.1mm	ISSUE	DATE	DESCRIPTIONS OF REVISION	APPD.
5	CONTACT CLIP	PBS	6	Ag PLATED	OVER : 1.5±0.2mm				
4	KNOB	NYLON+F.G+94V0	1	BLACK	TITLE : PUSH SWITCH			UNIT : mm	DRWG NO.: XJ-DR-PS62D03-00
3	FRAME	STEEL STRIP	1	Ni PLATED	MODEL: PS-62D03			SCALE: 3:2	DWN. ZHOUYU 2001-12-26
2	BASE	PHENOLIC RESIN	1	NATURAL	ALL MATERIALS MUST BE COMPLIANT TO ROHS			CHK'D FANGYING	2001-12-26
1	TERMINAL	BRASS STRIP	18	Ag PLATED OVER Ni PLATED				APPD. KANGXINAN	2001-12-26
NO.	PARTS	MATERIALS	Q'TY	FINISH					